

ON TOPOLOGICAL INVARIANTS OF REAL ALGEBRAIC FUNCTIONS

V.A. VASSILIEV

To the memory of Vladimir Igorevich Arnold

ABSTRACT. We consider a natural covering responsible for the complexity of the ramification of roots of the general real polynomial equation, and calculate the homology groups of its base; for equations of degree ≤ 5 we give a complete description of the topology of this base.

The general complex d -valued entire algebraic function $x = F(a_1, \dots, a_d)$, given by the equation

$$(1) \quad x^d + a_1 x^{d-1} + \dots + a_{d-1} x + a_d = 0,$$

is ramified at the *discriminant variety* $\Sigma_{\mathbb{C}} \subset \mathbb{C}^d$, consisting of collections of coefficients (a_1, \dots, a_d) , for which the polynomial (1) has multiple roots, see. [1], [5]. The complement of this variety in \mathbb{C}^d is the base of two standard coverings: d -fold and $d!$ -fold ones. The fundamental group of this complement acts on the sets of roots of the equation (1) and generates the entire permutation group of these roots. V.I. Arnold has exploited the homology classes of this complement $\mathbb{C}^d \setminus \Sigma_{\mathbb{C}}$ as obstructions to inducing one algebraic functions from the others. Also, the study of these homology groups provides lower estimates on the *Schwarz genus* of corresponding coverings, i.e. on the minimal number of open subsets covering the base, over any of which the covering has a continuous section, see [7], [8]. In [8], [9] these estimates are applied to the study of the topological complexity of approximate solution of the general equation (1).

If we consider only real equations (1), then a similar role will be played by coverings defined on the complement of a certain subset of real codimension 2 in the space \mathbb{R}^d of such equations. Namely, this subset Υ consists of polynomials having either a real root of multiplicity ≥ 3 , or a couple of imaginary complex conjugate roots of multiplicity ≥ 2 . For $d = 4$ this set in the space of reduced (i.e. with $a_1 = 0$) polynomials (1) is represented by three branches of curves, going from the origin to the infinity and distinguished in the left-hand part of Fig. 1: two branches of the cuspidal edge of the swallowtail (see e.g. [2]) and the continuation of its self-intersection line.

The monodromy of these coverings generates not the entire permutation group of d roots, but only the subgroup of even permutations. As in the complex case, the topology of these coverings provides lower estimates on the numbers of branchings of algorithms solving real equations (1); already for $d = 3$ this calculation proves the necessity of such branchings.

In §4 we calculate integral homology groups of all spaces $\mathbb{R}^d \setminus \Upsilon$.

Supported by grant NSh-8462.2010.1 of President of Russia for the support of leading scientific schools.

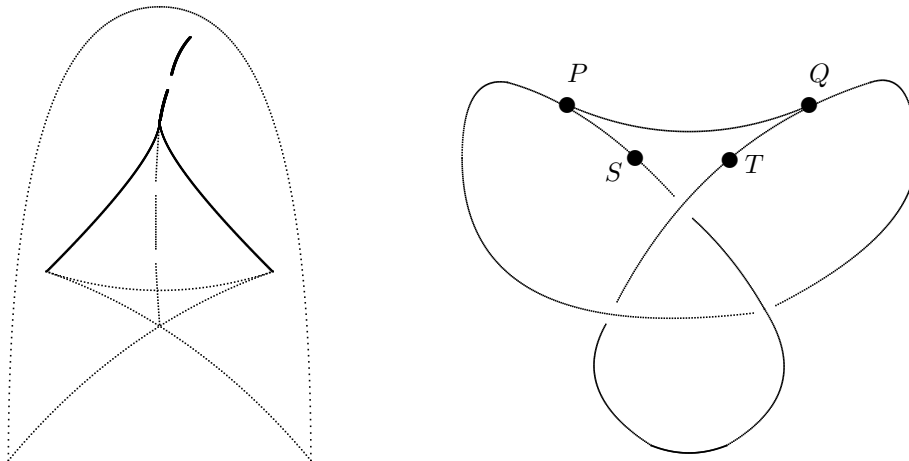

FIGURE 1. The variety of essential ramification for $d = 4$ and 5

In §2 these coverings are described in the simplest cases $d = 3$ and 4 . In §3 we find the topological type of the set Υ (as an embedded subset in \mathbb{R}^d) for $d = 5$. Namely, we reduce this problem to the study of the intersection of this set with a sphere S^3 surrounding the origin in the space of reduced polynomials

$$(2) \quad x^5 + Ax^3 + Bx^2 + Cx + D$$

and prove the following theorem.

Theorem 1. *For $d = 5$ the intersection of the set Υ with S^3 is isotopic to the figure shown in the right-hand part of Fig. 1. In this picture:*

- *points P and Q correspond to polynomials with roots of multiplicity 4;*
- *the shortest curvilinear interval (P, Q) consists of polynomials with a three-fold root placed between two other real roots;*
- *the longer curvilinear interval (P, Q) , not containing the points S and T , consists of polynomials with two-fold imaginary roots;*
- *points S and T denote two polynomials each having one two-fold and one three-fold root;*
- *intervals (P, S) and (Q, T) consist of polynomials with one three-fold root, greater (respectively, smaller) than two other real roots;*
- *the curvilinear interval (S, T) , not containing the points P and Q , consists of polynomials with a three-fold real root and two imaginary roots.*

The behavior of three branches of Υ at the points P and Q repeats the behavior at the origin of three distinguished branches in the left-hand part of Fig. 1.

Corollary 1. *The complement of the set Υ in S^3 is homotopy equivalent to a one-dimensional complex.*

Remark 1. The right-hand part of Fig. 1 is an expansion of Figure 28 from §2.5 of [3] (describing in detail the upper central domain of this part of Fig. 1). The essential part of this expansion is the behavior of the “fantom” ramification line,

consisting of polynomials with imaginary double roots, with respect to the real part.

1. BASIC COVERING Θ_d

The space $\mathbb{C}^d \setminus \Sigma_{\mathbb{C}}$ of complex polynomials (1), all whose roots are different, is the base of the obvious d -fold covering

$$(3) \quad \varphi_d : M_{\mathbb{C}}^d \rightarrow \mathbb{C}^d \setminus \Sigma_{\mathbb{C}},$$

whose fibre over the polynomial f is the set of pairs consisting of the polynomial f and one of its roots.

Definition 1. *The essential ramification set Υ in the space \mathbb{R}^d of real polynomials (1) is the union of the set of polynomials with at least one real root of multiplicity ≥ 3 and the set of polynomials with at least one pair of conjugate imaginary roots of multiplicity ≥ 2 . The last two sets will be denoted by \clubsuit and \dagger respectively.*

It is obvious that all these sets have codimension 2 in \mathbb{R}^d .

Proposition 1. *The restriction of the covering φ_d to the set $\mathbb{R}^d \setminus \Sigma_{\mathbb{C}}$ can be continued to a covering over the set $\mathbb{R}^d \setminus \Upsilon$.*

Indeed, the additional set $(\mathbb{R}^d \cap \Sigma_{\mathbb{C}}) \setminus \Upsilon$, to which the covering φ_d should be continued, consists of polynomials, having several real roots of multiplicity exactly 2. If such a polynomial f_0 has exactly k double roots $q_1 < \dots < q_k$, then the set $\mathbb{R}^d \cap \Sigma_{\mathbb{C}}$ close to the point f_0 is ambient diffeomorphic to the direct product of the space \mathbb{R}^{d-k} and the union of coordinate planes in \mathbb{R}^k . When a polynomial moves in a neighborhood of such a polynomial $f_0 \in \mathbb{R}^d$, the pairs of close real roots can collide and exit to the complex domain. Define the $2k$ -fold trivial covering over such a small neighborhood U , i.e. the product of U and the set of $2k$ points $r_1^+, r_1^-, \dots, r_k^+, r_k^-$. Suppose that $f \in U$ does not belong to $\Sigma_{\mathbb{C}}$, and for some $i \in \{1, \dots, k\}$ f has two real roots, obtained by the decomposition of the root q_i of f_0 . Then we identify the point $(f, \text{the bigger of these roots}) \in M_{\mathbb{C}}^d$ with the point $f \times r_i^+$ of this product, and the point $(f, \text{the smaller root})$ with $f \times r_i^-$. In a similar way, if f has two imaginary roots, obtained by the decomposition of q_i , then we identify the point $(f, \text{the root with the positive imaginary part}) \in M_{\mathbb{C}}^d$ with $f \times r_i^+$, and the point $(f, \text{the root with the negative one})$ with $f \times r_i^-$. This identification continues $2k$ sheets of our covering φ_d to entire neighborhood U , and the remaining $d - 2k$ sheets are continued there in the obvious way. These continuations are compatible for all points of the set $(\mathbb{R}^d \cap \Sigma_{\mathbb{C}}) \setminus \Upsilon$. \square

Let us denote this extended covering as follows: $\Theta_d : M_{\mathbb{R}}^d \rightarrow \mathbb{R}^d \setminus \Upsilon$.

Remark 2. Here is another description of this covering. Any local (close to f_0) irreducible component of the set $(\mathbb{R}^d \cap \Sigma_{\mathbb{C}}) \setminus \Upsilon$ is non-singular and is transversally oriented to the side in which the corresponding two-fold root splits into two real ones. Define a smooth vector field v in \mathbb{R}^d , which is equal to 0 outside of a small neighborhood of this set, in particular on Υ , transversal to all these local components and crossing them in the positive direction. Then move $\mathbb{R}^d \setminus \Upsilon$ in the complex area, sending any point f into $f + iv(f)$. If appropriate restrictions on the length of v will be satisfied, then this map will imbed all of $\mathbb{R}^d \setminus \Upsilon$ into $\mathbb{C}^d \setminus \Sigma_{\mathbb{C}}$. The covering Θ_d is equivalent to one induced by this shift from the covering (3).

The covering Θ_d defines the monodromy representation $m_d : \pi_1(\mathbb{R}^d \setminus \Upsilon) \rightarrow S(d)$, where $S(d)$ is the group of permutations of some distinguished polynomial (for which it is convenient to choose some polynomial with d different real roots). The description of the covering Θ_d , given in Remark 2, is in a sense more convenient than the original one, since it fixes not only the monodromy representation into the group of permutations of d roots, but also its lifting $\bar{m}_d : \pi_1(\mathbb{R}^d \setminus \Upsilon) \rightarrow Br(d)$ into the *braid group on d strings* (for whose definition see, e.g., [2], [10]).

Proposition 2. *For any d , the image of representation $m_d : \pi_1(\mathbb{R}^d \setminus \Upsilon) \rightarrow S(d)$ coincides with the subgroup $A(d)$ of even permutations. The image of the lifting \bar{m}_d of this representation belongs to the subgroup of braids of zero twistedness.*

Proof. Let us say that a polynomial $f \in \mathbb{R}^d \setminus \Sigma_{\mathbb{C}}$ is generic if none real number is the real part of more than two roots of f . For any such f , let us number all its roots in the order of increase of their real parts, and in the case of coincidence of the latter in the order of increase of imaginary parts. There are exactly two kinds of surgeries of generic polynomials, arising in the paths of general position in the space $\mathbb{R}^d \setminus \Upsilon$ and providing a discontinuous change of this numeration of sheets of the covering $M_{\mathbb{R}}^d$ over f : collision of real parts of one real and two imaginary roots, and collision of real parts of two pairs of imaginary roots. (Note, that the collision of two real roots and their exit to the complex domain, as well as the converse action, do not are the surgeries providing such a renumbering). Any of these surgeries defines an even renumbering of roots and, moreover, a braid of zero twistedness, which is the product of two elementary braids of opposite signs. On the other hand, the following permutations can be easily realized by the action of the monodromy group of our covering: any cyclic permutations of triples of neighboring elements, $(i-1, i, i+1) \mapsto (i+1, i-1, i)$, and permutations of pairs of neighboring elements, $((i, i+1), \dots, (j, j+1)) \mapsto ((j, j+1), \dots, (i, i+1))$. Indeed, to realize a permutation of the first type, we can approach a polynomial with colliding roots No. $i-1, i, i+1$ inside the set of polynomials with d real roots, and turn in \mathbb{R}^d around the corresponding stratum of polynomials with triple roots. To realize a permutation of second type, we can collide the corresponding pairs of roots, move them into the complex domain, and permute them there in the simplest way. Permutations of these two types are enough to generate the entire group $A(d)$. \square

In [8] it was actually shown (although explicitly it was formulated only later in [9]), that the *topological complexity* (i.e. the minimal number of branchings of algorithms) of approximate calculation of one root of any complex polynomial (1) is estimated from below by the decreased by 1 Schwarz genus of the covering (3). This statement (essentially together with the proof) can be transferred to the problem of approximate solution of any real equation of the form (1) (certainly, this problem is actual only for odd d).

Proposition 3 (cf. [8]). *For any odd d and a compact $D \subset \mathbb{R}^d$, containing a neighborhood of the origin, there is $\varepsilon(D) > 0$ such that the number of branchings (i.e. IF operators) of any algebraic algorithm, calculating with precision $\leq \varepsilon$ a real root of any equation (1) with $(a_1, \dots, a_d) \in D$, is not less than the genus of the covering Θ_d minus 1.* \square

2. FIRST REDUCTION AND SIMPLEST EXAMPLES: $d = 3$ AND 4

The group \mathbb{R}^1 of translations of the argument acts freely on the space of polynomials (1) by the rule $t : f(x) \mapsto f(x - t)$, preserving the entire stratification of this space by multiplicities and reality of roots. Any orbit of this action once transversally intersects the subspace consisting of polynomials (1) with $a_1 = 0$. The fibration of the space of all polynomials into these orbits provides a diffeomorphism (also preserving this stratification) of \mathbb{R}^d to the product of the line \mathbb{R}^1 and this subspace \mathbb{R}^{d-1} . Therefore it is sufficient to consider only this subspace and the restriction of the covering Θ_d onto $\mathbb{R}^{d-1} \setminus \Upsilon$.

2.1. **The case $d = 3$.** In this case we have the space of polynomials $x^3 + px + q$. It is divided by the discriminant curve $\{(\frac{p}{3})^3 + (\frac{q}{2})^2 = 0\}$ into two non-equal parts, all polynomials from the smaller of them having three real roots each, and all polynomial from the bigger part having only one. The set Υ in this space is represented by unique point: the origin. It is easy to check that one turn around this point, starting and finishing at a point with three real roots, defines a cyclic permutation of these roots. In particular, the Schwarz genus of the covering Θ_3 over $\mathbb{R}^2 \setminus \Upsilon$ is equal to 2.

2.2. **The case $d = 4$.** In this case the discriminant subset in \mathbb{R}^3 is the *swallowtail*, see the left-hand part of Fig. 1. The set $\Upsilon \cap \mathbb{R}^3$ consists of three non-knotted curves, going from the origin to the infinity: two branches of the cuspidal edge A_2 and the analytic continuation of the self-intersection of the swallowtail; the visible part of the self-intersection, consisting of manifolds having two real roots of multiplicity 2, does not belong to the set Υ . The simplest loops in $\mathbb{R}^3 \setminus \Upsilon$, starting and finishing at some polynomial with four real roots and embracing these three curves, define the following permutations of these roots: $(1, 2, 3, 4) \mapsto (2, 3, 1, 4); (1, 3, 4, 2)$ and $(3, 4, 1, 2)$ respectively. These permutations are obviously even, dependent, and generate the group $A(4)$. The Schwarz genus of the covering Θ_4 over $\mathbb{R}^3 \setminus \Upsilon$ is not less than 2 (which simply means that this covering has no global sections). But it cannot also exceed 2, because the base of this covering is homotopy equivalent to an one-dimensional complex, see [7].

In a similar way, Corollary 1 implies that the genus of covering Θ_5 also is equal to 2. This is consistent with the result of [11] that the topological complexity of approximate solution of the general equation (2) is equal to 1. On the other hand, in [12] it is shown that for equations of degree 7 this complexity is not less than 2, therefore the case $d = 7$ is a candidate for the next growing of the Schwarz genus of the covering Θ_d (to three).

3. PROOF OF THEOREM 1

3.1. **Inner topology of the essential ramification set.** The group \mathbb{R}_+^1 of positive dilations of the argument acts on the space of polynomials (1) by the rule

$$(4) \quad \mathbb{R}_+^1 \ni \lambda : f(x) \mapsto \lambda^{-d} f(\lambda x).$$

This action is free on $\mathbb{R}^{d-1} \setminus 0$ and again respects the entire combinatorial stratification of the set of polynomials. Any orbit of this action once transversally crosses the boundary S^{d-2} of any ball with center at $0 \in \mathbb{R}^{d-1}$, and we obtain a diffeomorphism $\mathbb{R}^{d-1} \setminus 0 \simeq S^{d-2} \times \mathbb{R}_+^1$. Therefore for $d = 5$ it is sufficient to consider such a sphere S^3 in the space of polynomials (2) and its intersection with the set Υ . For

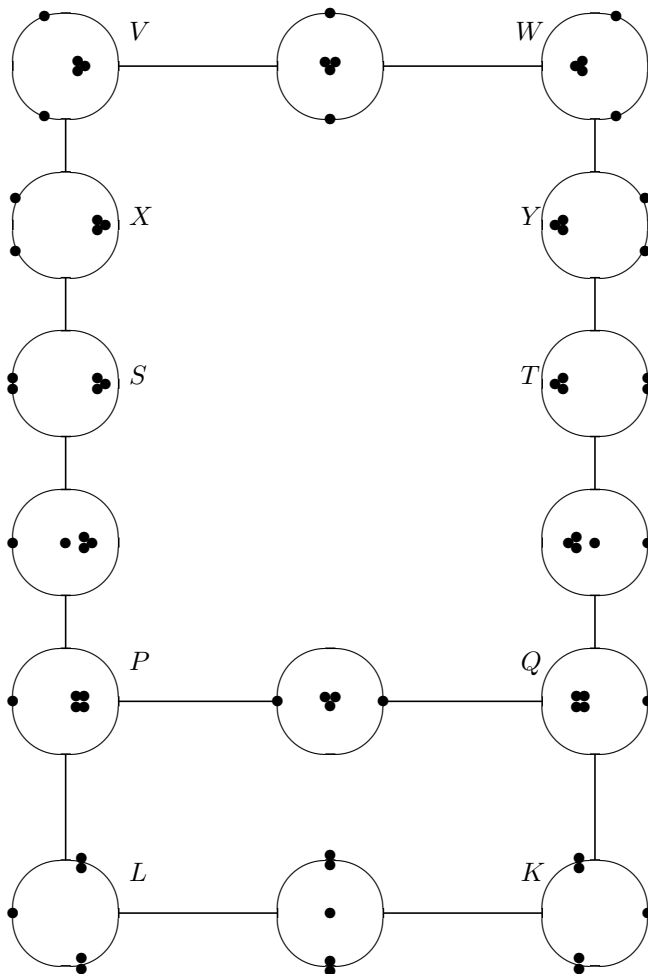

FIGURE 2. Inner topology of the essential ramification set

such a sphere we can take the set of all polynomials, the absolute values of all whose roots do not exceed 1 and at least one of these absolute values is equal to 1; the sum of all these roots should be equal to 0. (This sphere is not a smooth submanifold in \mathbb{R}^4 , but we consider it as a realization of the quotient space $(\mathbb{R}^{d-1} \setminus 0)/\mathbb{R}_+^1$ with the corresponding smooth structure).

Proposition 4. *The intersection of the essential ramification set $\Upsilon \in \mathbb{R}^5$ for the general algebraic function of 5-th degree and the sphere S^3 in the space of polynomials (2) is homeomorphic to the figure \ominus . The singular points of this figure correspond to the polynomials with 4-fold roots.*

Proof of this statement consists in counting all non-ordered sets of five points in the unit disc of \mathbb{C}^1 , symmetric with respect to the real axis and having zero center of gravity, and such that at least one of points is placed on the boundary of the disc, and either some three points do coincide, or there are two conjugate pairs of coinciding points. This counting is given in 2. Here the letters P, Q, S, T denote the

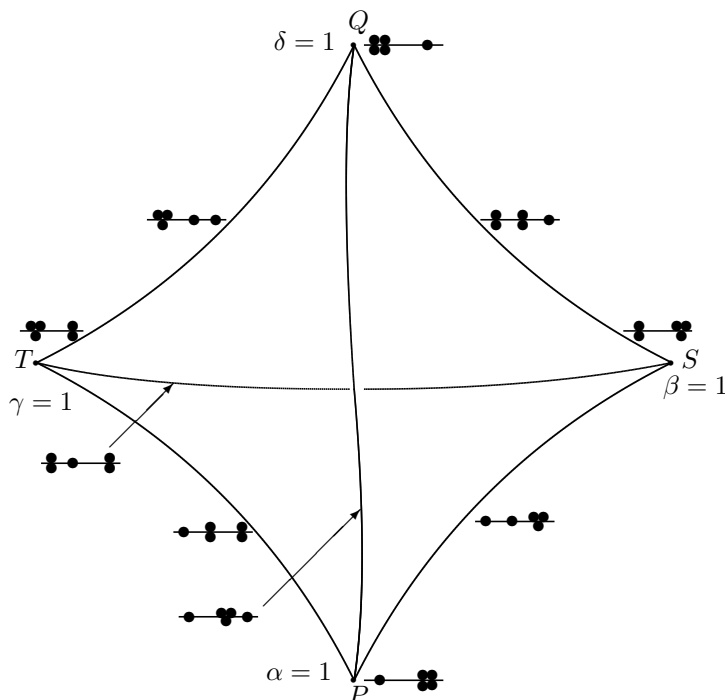

FIGURE 3. Degree 5 polynomials with five real roots

same polynomials as in Theorem 1 and Fig. 1; the sense of letters L, K, X, V, W, Y will be explained later. \square

It remains to understand, how this graph \bigcirc is embedded into S^3 .

3.2. Central simplex. The most interesting part of our sphere S^3 is the set of polynomials with 5 real roots. This set is canonically homeomorphic to the standard three-dimensional simplex: if we denote by $r_1 < r_2 < \dots < r_5$ the values of roots of a polynomial, then the barycentric coordinates of the point corresponding to this polynomial are $\alpha \equiv \frac{r_2 - r_1}{r_5 - r_1}, \beta \equiv \frac{r_3 - r_2}{r_5 - r_1}, \gamma \equiv \frac{r_4 - r_3}{r_5 - r_1}, \delta \equiv \frac{r_5 - r_4}{r_5 - r_1}$. This homeomorphism is not an ambient diffeomorphism, see Fig. 3: for instance, close to the vertices $\alpha = 1$ and $\delta = 1$ (or, in the terms of Fig. 2, points P and Q) this simplex is diffeomorphic to the interior pyramid of the swallowtail, and close to the edges $\{\gamma = \delta = 0\}, \{\alpha = \beta = 0\}$ and $\{\beta = \gamma = 0\}$ it is diffeomorphic to the smaller of two domains bounded by the surface with semicubical cuspidal edge. These three edges are represented in Fig. 2 by segments $[PS], [QT]$ and $[PQ]$ respectively.

It remains to understand how the remaining two segments of the curve Υ are knotted.

We will consider our sphere S^3 as the quotient space of the space $\mathbb{R}^4 \setminus 0$ of polynomials (2) by the action (4). Notice, that the set $\Upsilon \cap \mathbb{R}^4 \setminus 0$ does not contain the axis D of \mathbb{R}^4 . Remove from our quotient space S^3 two points, corresponding to halves of this axis. The remaining manifold is a trivial fiber bundle over S^2 with fiber \mathbb{R}^1 , where S^2 can be considered as the quotient space of the space of polynomials $x^5 + Ax^3 + Bx^2 + Cx$ through the action of the group \mathbb{R}_+^1 of dilations $\lambda : f(x) \mapsto \lambda^{-5}f(\lambda x)$.

Let us find pairs of points of the set Υ (i.e. of orbits of the action (4)), having equal projections to S^2 , i.e. different only by the constant terms of corresponding polynomials.

3.3. Self-intersection of the projection of the set \clubsuit of polynomials with triple real roots. Let us find pairs of polynomials (2) having triple real roots and different only by their constant terms. The common derivative of such a polynomial should have two two-fold roots, i.e. to be equal to

$$\rho(x-a)^2(x-\tilde{a})^2$$

for appropriate a, \tilde{a}, ρ . The coefficients of the initial polynomial (i.e. the integral of this derivative) at the monomials of degrees 5 and 4 are equal respectively to 1 and 0, hence $\rho = 5, a + \tilde{a} = 0$. Then this initial polynomial is equal to

$$(5) \quad x^5 - \frac{10}{3}a^2x^3 + 5a^4x$$

up to the constant term.

To find the value of the constant term, for which this polynomial has a triple root, let us equate it to the polynomial

$$(6) \quad (x-b)^3(x^2+3b+c) = x^5 + (c-6b^2)x^3 + (8b^3-3bc) + (3b^2c-3b^4) - b^3c.$$

The equality of coefficients of polynomials (5) and (6) at monomials x^3, x^2 and x gives us the conditions $a^2 = b^2, 3c = 8b^2$, so our polynomials have the form $(x-b)^3(x^2+3bx+\frac{8}{3}b^2)$, $b = \pm a$. Positive and negative values of b give us two different orbits of the action (4), i.e. two points of the sphere S^3 . Denote by X (respectively, Y) such a point, corresponding to the positive (respectively, negative) value of b . The discriminant of the polynomial $x^2+3bx+\frac{8}{3}b^2$ is negative, hence both these points belong to the interval (S, T) of the set Υ , shown in the upper part of Fig. 2. Moreover X belongs to the left-hand part of this picture (where the three-fold root is positive), and Y in the right-hand one. The polynomials constituting X have negative constant terms, and Y positive ones, hence in the diagram of the knot Υ in S^2 the point Y is placed above X .

3.4. The phantom curve \dagger is projected injectively. Let us prove that the subset in Υ , consisting of polynomials with two complex conjugate imaginary roots of multiplicity 2, is projected injectively into S^2 . The polynomials (2), having such roots, should be equal to

$$(7) \quad (x^2+ax+b)^2(x-2a) \equiv x^5+x^3(2b-3a^2)+x^2(-2ab-2a^3)+x(b^2-4a^2b)-2ab^2$$

for some a, b , such that

$$(8) \quad a^2 < 4b.$$

Suppose that there exists another polynomial of the same form, i.e. equal to

$$(9) \quad (x^2+cx+d)^2(x-2c) \equiv x^5+x^3(2d-3c^2)+x^2(-2cd-2c^3)+x(d^2-4c^2d)-2cd^2,$$

coinciding with this one up to the constant term. The condition of their coincidence gives us the system of equations

$$(10) \quad 2b-3a^2=2d-3c^2; \quad ab+a^3=cd+c^3; \quad b^2-4a^2b=d^2-4c^2d.$$

Excluding the variables b and d and rejecting the solutions implying the total coincidence of these polynomials, we obtain the equality

$$13a^2 + 10ac + 13c^2 = 0,$$

non-solvable in the real domain. Hence this part of the set Υ is indeed projected into S^2 without self-intersections.

3.5. Intersections of projections of curves † and ♣. Now let us count the points in S^2 , which are the projections of both “fantom” ramification points (i.e. polynomials of the form (7)), and polynomials with three-fold real roots. Polynomials of the latter type should have the form

$$(11) \quad (x-c)^3(x^2+3cx+d) \equiv x^5 + x^3(d-6c^2) + x^2(8c^3-3cd) + x(3c^2d-3c^4) - c^3d.$$

Equating the coefficients of polynomials (11) and (7) at monomials x^3, x^2, x , we obtain the system of equations

$$(12) \quad 2b - 3a^2 = d - 6c^2; \quad -2(ab + a^3) = 8c^3 - 3cd; \quad b^2 - 4a^2b = 3c^2d - 3c^4.$$

Excluding b and d , we get an equation on a and c :

$$20a^6 + 60a^5c - 75a^4c^2 - 300a^3c^3 + 240ac^5 - 80c^6 = 0.$$

Let be $t = a/c$, then

$$4t^6 + 12t^5 - 15t^4 - 60t^3 + 48t - 16 \equiv (t+2)^3(t-2)(2t-1)^2 = 0.$$

The solution $t = -2$ gives us

$$a = -2c, \quad b = c^2, \quad d = -4c^2.$$

Then the polynomials (7) and (11) coincide and are equal to

$$x^5 - 10c^2x^3 + 20c^3x^2 - 15c^4x + 4c^5 \equiv (x-c)^4(x+4c),$$

so it are just the common endpoints P, Q of the considered intervals of the set Υ .

The solution $t = 1/2$ gives us

$$c = 2a, \quad b = -6a^2, \quad d = 9a^2.$$

Then the polynomials (7) and (11) coincide with one another and are equal to

$$x^5 - 15a^2x^3 + 10a^3x^2 + 60a^4x - 72a^5 \equiv (x-2a)^3(x+3a)^2,$$

so it are the vertices S and T of the simplex from Fig. 3. These points obviously do not satisfy the discriminant condition (8).

The solution $t = 2$ gives us

$$a = 2c, \quad b = 21c^2, \quad d = 36c^2.$$

Then the polynomial (7) is equal to

$$x^5 + 30c^2x^3 - 100c^3x^2 + 105c^4x - 1764c^5,$$

and the polynomial (11) is almost the same, but with the constant term $-36c^5$.

The families of such manifolds, corresponding to positive and negative values of c , define different pairs of points in S^3 , which are projected into different points of S^2 . Denote by K and L the fantom (i.e. belonging to the set †) polynomials of these pairs, and by V and W the polynomials belonging to ♣, corresponding to positive and negative values of c respectively. Then the point V on the knot diagram is placed above K , and the point L above W .

So, we have four interesting points on the interval (S, T) in the upper part of Fig. 2: (Y) the upper and (X) the lower pre-images of the self-intersection point of the projection of this interval into S^2 , (V) a pre-image of the intersection point of projections of sets \dagger and \clubsuit , described in the previous paragraph and corresponding to positive values of c , and (W) a pre-image of a similar point, corresponding to negative values of c . The points X and V are placed in the part of Υ , depicted in Fig. 2 on the left, and the points Y and W on the right.

Proposition 5. *These points are placed on the segment $[S, T]$ in the upper part of Fig. 2 in the following order: S, X, V, W, Y, T .*

Proof. On this segment, the argument of the complex root with positive imaginary part of the corresponding polynomial decreases monotonically from π to 0. It is easy to check that these imaginary parts for polynomials realizing our points are ordered in exactly this way. \square

By our previous calculations, the polynomials X and Y (respectively, K and V , respectively, W and L) coincide up to the constant term; in any of these three pairs its second element has a greater constant term. This terminates the description of the diagram of the projection of the essential ramification set $\Upsilon \cap S^3$ into S^2 up to isotopies in S^2 , in particular terminates the proof of Theorem 1. \square

4. HOMOLOGY GROUPS OF THE COMPLEMENT OF ESSENTIAL RAMIFICATION SET

Theorem 2. *For any d and any group $G = \mathbb{Z}$ or \mathbb{Z}_q ,*

$$(13) \quad H_i(\mathbb{R}^d \setminus \Upsilon, G) \simeq \bigoplus_{\substack{k \geq 0 \leq m, \\ 3k + 4m \leq d}} H_{i-k-m}(B(\mathbb{C}_+^1, m), \pm G),$$

where $B(\mathbb{C}_+^1, m)$ is the space of all m -element subsets in the upper half-plane $\mathbb{C}_+^1 \equiv \{z : \text{Im} z > 0\}$, $\pm G$ is the local system of groups on this space, locally isomorphic to G , but reversing its orientation over the loops in the base, defining an odd permutation of m points.

The spaces $B(\mathbb{C}_+^1, m)$ participating in this formula are the classifying spaces of braid groups; their homology groups are well-known, see e.g. [10].

Example 1. *For $d = 5, 6, 7, 8, 9$ and $G \neq \mathbb{Z}_2$, Poincare polynomials of G -free parts of groups $H_*(\mathbb{R}^d \setminus \Upsilon, G)$ are equal to $1 + 2t$, $1 + 2t + t^2$, $1 + 2t + 2t^2$, $1 + 2t + 2t^2$, $1 + 2t + 2t^2 + t^3$ respectively. For $d < 8$ (and if $G = \mathbb{Z}_q$, q odd, then also for $d = 8$ and 9) these groups are free G -modules. For $d = 8$ or 9 and $G = \mathbb{Z}$ (respectively, \mathbb{Z}_q with even $q \neq 2$) this group contains additional summand \mathbb{Z}_2 in dimension 2 (respectively, in dimensions 2 and 3). If $G = \mathbb{Z}_2$ then for $d = 5, 6, 7$ the Poincare polynomials of these groups are the same as above; for $d = 8$ and 9 these polynomials are equal to $1 + 2t + 3t^2 + t^3$ and $1 + 2t^2 + 3t^2 + 2t^3$ respectively. \square*

Proof of Theorem 2 follows the standard scheme from [10], based on the simplicial resolution of the set Υ . In particular, the formula (13) can be realized in the following way (cf. [10], §III.6). Let γ be an arbitrary cycle, representing some element of the group $H_{i-k-m}(B(\mathbb{C}_+^1, m), \pm G)$. Its support is compact, therefore there is $\varepsilon > 0$ such that for any point of this cycle (i.e. a collection of m points in \mathbb{C}_+^1) all these m points are $\geq 5\varepsilon$ -distant from one another and from the real

axis. For any such point (z_1, \dots, z_m) consider an embedded m -dimensional torus in $B(\mathbb{C}_+^1, 2m)$, consisting of all possible $2m$ -configurations of the form $(z_1 + \varepsilon e^{i\alpha_1}, z_1 - \varepsilon e^{i\alpha_1}, \dots, z_m + \varepsilon e^{i\alpha_m}, z_m - \varepsilon e^{i\alpha_m})$ with all possible $\alpha_1, \dots, \alpha_m \in [0, \pi)$. Any point of such a torus defines a point of the space $\mathbb{R}^{4m} \setminus \Upsilon_{4m}$, namely a real polynomial of degree $4m$ with coefficient 1 at x^{4m} , whose roots run over the corresponding $2m$ -configuration and the configuration complex conjugate to it. So, our torus becomes embedded into $\mathbb{R}^{4m} \setminus \Upsilon_{4m}$. The union of such tori over all $(z_1, \dots, z_m) \in \gamma$ sweeps out some $(i - k)$ -dimensional G -cycle Γ in this space. In addition, consider the standard k -dimensional torus $T^k \subset \mathbb{R}^{3k} \setminus \Upsilon_{3k}$, consisting of all polynomials of the form

$$((x-1)^3 + \cos(\beta_1)\varepsilon^2(x-1) + \sin(\beta_1)\varepsilon^3) \cdots ((x-k)^3 + \cos(\beta_k)\varepsilon^2(x-k) + \sin(\beta_k)\varepsilon),$$

where ε is small, and β_1, \dots, β_k run independently over the segment $[0, 2\pi]$. The direct product $\Gamma \times T^k$ is embedded into $\mathbb{R}^d \setminus \Upsilon$: with any pair of points $\phi \in \Gamma, \psi \in T^k$ the polynomial

$$\phi \times \psi \times (x - N)(x - 2N) \cdots (x - (d - 3k - 4m)N)$$

is associated, where N is a sufficiently large number, exceeding both $k + 1$ and the maximal value of absolute values of all points in \mathbb{C}_+^1 , participating in configurations, constituting the cycle γ . The image of this embedding defines an i -dimensional cycle, whose homology class is the desired class in $H_i(\mathbb{R}^d \setminus \Upsilon, G)$, corresponding to γ via the equality (13).

The simplicial resolution for Υ , constructed along the scheme from [10], gives a spectral sequence for calculating the groups $H_i(\mathbb{R}^d \setminus \Upsilon, G)$; the sum of its terms $E_{p,q}^1$ is equal to the right-hand part of (13), and the described realization of all these summands by cycles proves the stabilization at this term. \square

Remark 3. By the Alexander duality theorem, homology groups of the space $\mathbb{R}^d \setminus \Upsilon$ with constant coefficients can be reduced to the inner topology of the set Υ and say nothing on its knottedness in \mathbb{R}^d .

For estimating the Schwarz genus not the integer homology groups of spaces $\mathbb{R}^d \setminus \Upsilon$ are most interesting, but the homology groups of appropriate local systems associated with the covering Θ_d , see [7], [9]. In particular, the homotopy type of these spaces is important.

Also, similarly to [1], the topological invariants of sets of essential ramification (and of this ramification itself) can be used as obstructions to inducing real algebraic functions from one another.

Finally, let me mention works [4], [6], adjoining this problematic.

REFERENCES

- [1] V.I. Arnold, Topological invariants of algebraic functions. II. *Funct. Anal. and its Appl.* 4:2 (1970), 1–9.
- [2] V.I. Arnold, V.V. Goryunov, O.V. Lyashko, V.A. Vasil'ev, *Singularity Theory I*. 2nd ed. Springer, Berlin a.o., 1998, 245 pp.
- [3] V.I. Arnold. *Singularities of Caustics and Wave Fronts*. Kluwer, Dordrecht-Boston-London, 1990. Russian Transl.: Phasis, Moscow, 1996, 334 pp.
- [4] M.G. Khovanov, Real $K(\pi, 1)$ -arrangements from finite root systems, *Mathematical Research Letters* 3 (1996), 261–274.
- [5] F. Klein, *Vorlesungen über das Ikosaeder und die Auflösung der Gleichungen vom fünften Grade*. Leipzig, 1884.

- [6] E.J.N. Looijenga, The discriminant of a real simple singularity, *Compositio Math.*, 37:1 (1978), 51–62.
- [7] A.S. Schwarz, Genus of a fiber bundle, *Trudy (Transact.) Moscow Math. Society* 10 (1961), 217–272.
- [8] S. Smale, On the topology of algorithms. *J. of Complexity* 3 (1987), 81–89.
- [9] V.A. Vassiliev, Cohomology of braid groups and complexity of algorithms, *Funct. Anal. and its Appl.*, 22:3 (1988), 15–24.
- [10] V.A. Vassiliev, *Topology of complements of discriminants*. Phasis, Moscow, 1997. XIII+536 pp.
- [11] V.A. Vassiliev, Topological complexity and reality, *Matem. Zametki (Math. Notes)* 60:5 (1996), 270–280.
- [12] V.A. Vassiliev, Topological complexity and Schwarz genus of general real polynomial equation, *Moscow Math. Journal* 11, 2011, ?.

STEKLOV MATHEMATICAL INSTITUTE AND MATHEMATICAL DEPARTMENT OF HIGHER SCHOOL OF ECONOMICS, MOSCOW, RUSSIA

E-mail address: `vva@mi.ras.ru`